



May 9, 2022

To whom it may concern:

Company Name: Nippon Telegraph and Telephone Corporation
 Name of Representative: Jun Sawada, President and Chief Executive Officer
 (Securities Code: 9432 Prime Market)

Notice Regarding Realignment to Strengthen the Global Business of NTT Group (Change in Lower-tier Subsidiaries)

Nippon Telegraph and Telephone Corporation (the “**Company**”) has resolved at its board of directors meeting held today that it will realign NTT group’s global business (the “**Realignment**”) by making NTT, Inc. (“**NTT, Inc.**”), a global holding company of the NTT group, and NTT Limited (“**NTT Ltd.**”), a wholly owned subsidiary of NTT, Inc. operating the global IT services and communications business, subsidiaries of NTT DATA Corporation (“**NTT DATA**”), a listed subsidiary of the Company, thereby grouping the global businesses operated under NTT, Inc. and NTT Ltd. with the global business operated by NTT DATA group, and has executed with NTT DATA a master agreement regarding the Realignment (the “**Master Agreement**”) and shareholders’ agreement. The Realignment is to be conducted for the purpose of strengthening global capabilities for business users and global governance by bringing together the global human resources and other resources of the NTT group. The Company announces changes in lower-tier subsidiaries (namely, NTT DATA, NTT, Inc., and the Newly-incorporated Company (as defined under “(4) Absorption-type Company Split of NTT DATA’s Domestic Business” in “2. Outline of the Realignment”) in connection with the Realignment as follows.

The Company also announces that it will acquire shares of NTT DATA up to 60 million shares or 100 billion yen through market transactions.

1. Purpose of the Realignment

(1) Background with respect to Conducting the Realignment

The NTT group incorporated NTT, Inc. in 2018 as an intermediary holding company that coordinates global businesses. In 2019, the NTT group reorganized its global business by integrating the global businesses operated respectively by NTT Communications group, Dimension Data group (as of 2019) and NTT Security group (as of 2019) as NTT Ltd. group under NTT, Inc. This allowed for the NTT group to accelerate growth of the global businesses operated by both NTT DATA group and NTT Ltd. group as “One NTT”. As a result, the NTT group has established presence as a unique global player that is able to deliver a wide range of offerings from applications to IT infrastructure. This has helped to drive growth in sales of the global business to approximately two trillion yen.

To increase the growth of the global business, the NTT group is accelerating the growth of digital services at NTT DATA and of high-value-added services at NTT Ltd. Also, in conjunction with these business shifts, structural reform is continuing in order to increase profitability.

Clients’ needs have become increasingly diverse and sophisticated in recent years, driving high

demand and growth for digital transformation (DX) and IT modernization services. In addition, the business environment is undergoing significant changes as competitors expand their service lines due to changes in societal demands and technologies.

(2) Purpose of Conducting the Realignment

To support the increasing demands in the business environment above the NTT group is moving the global businesses for business users operated by NTT DATA and NTT Ltd. within NTT DATA. This will allow for both companies to operate in a much more coordinated manner. By leveraging the combination of NTT DATA's capabilities such as consulting and application development and NTT Ltd.'s strength in high-value-added services such as data center, global networks, and managed infrastructure services, the NTT group will be able to provide clients with new value as a whole. Also, in the long term, the NTT group will expand its innovative services utilizing NTT's IOWN (Innovative Optical and Wireless Network) technology in global markets.

In addition, by bringing together the global talent of the NTT group, the NTT group will focus its human resources to realize more optimal and rapid decision making tailored to the needs of its business and clients in each region of the world while enhancing its global governance.

2. Outline of the Realignment

The Master Agreement provides for the procedures to conduct the Realignment as follows. After the Realignment NTT, Inc. will manage NTT Ltd. and other global subsidiaries as an operational company engaged in the global business for business users of the NTT group, and NTT Ltd. will continue to develop its existing business as a wholly owned subsidiary of NTT, Inc..

(1) Dividends in Kind, Etc.

NTT, Inc. holds 760,000,000 common shares (voting rights ownership ratio: 54.2% of the total number of voting rights as of September 30, 2021) of NTT DATA as of today, and will distribute all of these common shares of NTT DATA to the Company (the "**Dividends in Kind**") as dividends of surplus, which will become effective on October 1, 2022. As a result, NTT DATA will become a direct subsidiary of the Company and cease to be a lower-tier subsidiary of the Company.

Also, all common shares or interests in NTT Disruption Europe, S.L.U. ("**DS**"), NTT Global Sourcing, Inc. ("**GS**"), and NTT Venture Capital, L.P. ("**VC**") held by NTT, Inc. as of today are scheduled to be transferred through dividends in kind or other methods. to the Company by September 30, 2022.

(2) Absorption-type Company Split of NTT DATA's Global Business

On the condition that the Dividends in Kind and the Share Split (as defined below) become effective, Absorption-type Company Split (Global Business) (as defined below) is approved at the annual general shareholders meeting of NTT DATA to be held in June 2022, and permits and approvals from the relevant authorities are obtained as necessary, NTT DATA and NTT, Inc. will conduct an absorption-type company split with NTT DATA as the splitting company and NTT, Inc. as the successor company, which will become effective on October 1, 2022, in which NTT, Inc. will succeed to the rights and obligations regarding NTT DATA's global business from NTT DATA. NTT DATA will acquire 3,315 common shares of NTT, Inc. as consideration for that succession (the "**Absorption-type Company Split (Global Business)**"). As a result, 49% of

the issued common shares of NTT, Inc. will be held by the Company and 51% will be held by NTT DATA, and NTT, Inc. will become a subsidiary of NTT DATA.

Before the effective date of the Absorption-type Company Split (Global Business), NTT, Inc. will conduct a share split in which each common share of NTT, Inc. will be split into 49 shares (the “**Share Split**”), and thereby the number of issued shares of NTT, Inc. will increase from 65 shares to 3,185 shares.

NTT DATA and NTT, Inc. have executed today an absorption-type company split agreement regarding the Absorption-type Company Split (Global Business). For more details of the Absorption-type Company Split (Global Business), please see the announcement made by NTT DATA today titled “Notice Concerning Execution of Master Agreement and Shareholders Agreement with Nippon Telegraph and Telephone Corporation, and Execution of Absorption-Type Company Split Agreement with NTT, Inc., for Integration of NTT Group’s Overseas Business, Change of Largest and Major Shareholder and Change of Subsidiaries, and Transition to Holding Company Structure upon Company Split of Domestic Business and Establishment of Split Preparation Company”.

(3) Transfer of NTT, Inc.’s Shares from the Company to NTT DATA

On the condition that the Absorption-type Company Split (Global Business) becomes effective, the Company will transfer 260 common shares of NTT, Inc. owned by the Company to NTT DATA (the “**Share Transfer**”) and receive payment of 112 billion yen from NTT DATA as consideration therefor. As a result, 45% of the issued common shares of NTT, Inc. will be held by the Company and 55% will be held by NTT DATA.

(4) Absorption-type Company Split of NTT DATA’s Domestic Business

On the condition that the Absorption-type Company Split (Global Business) becomes effective and that the Share Transfer is consummated, NTT DATA will incorporate a split preparatory corporation as a wholly owned subsidiary of NTT DATA (the “**Newly-incorporated Company**”) on October 1, 2022, and will conduct an absorption-type company split with the Newly-incorporated Company with NTT DATA as the splitting company and the Newly-incorporated Company as the successor company, which will become effective on July 1, 2023, in which the Newly-incorporated Company will succeed to the rights and obligations regarding NTT DATA’s domestic business from NTT DATA (the “**Absorption-type Company Split (Domestic Business)**”). As a result, NTT DATA will become a holding company specializing in the formulation and execution of growth strategies from the viewpoint of optimization of the NTT DATA group as a whole and the control and management, etc. of the NTT DATA group, and shift to a holding company system in which NTT DATA holds NTT, Inc., which is an operational subsidiary operating the global business, and the Newly-incorporated Company, which is an operational subsidiary operating the domestic business.

For more details of the Absorption-type Company Split (Domestic Business), please see the announcement made by NTT DATA today titled, “Notice Concerning Execution of Master Agreement and Shareholders Agreement with Nippon Telegraph and Telephone Corporation, and Execution of Absorption-Type Company Split Agreement with NTT, Inc., for Integration of NTT Group’s Overseas Business, Change of Largest and Major Shareholder and Change of Subsidiaries, and Transition to Holding Company Structure upon Company Split of Domestic Business and Establishment of Split Preparation Company”.

The Company has retained Nomura Securities Co., Ltd. as its financial adviser, and Mori Hamada & Matsumoto as its legal advisor for the Realignment.

As of today

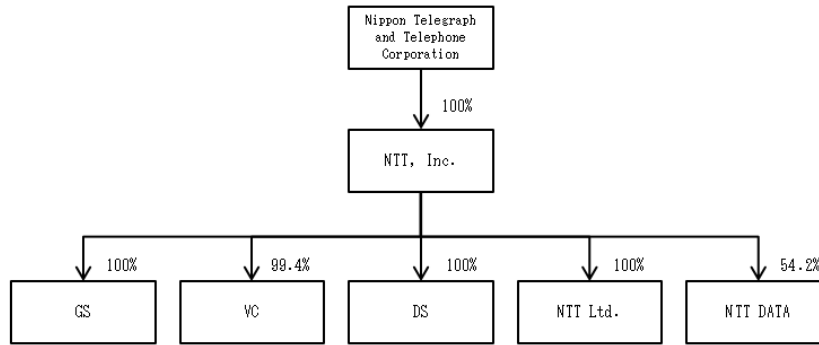

(1) Dividends in Kind, Etc.

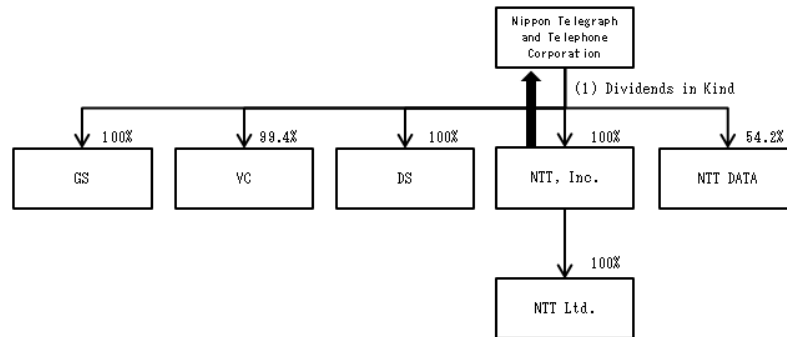

(2) Absorption-type Company Split of NTT DATA's Global Business

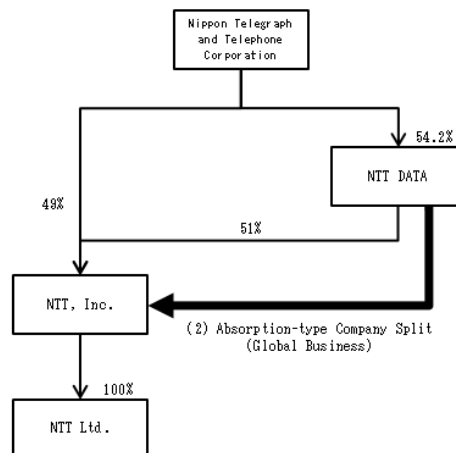

(3) Transfer of NTT, Inc.'s Shares from the Company to NTT DATA

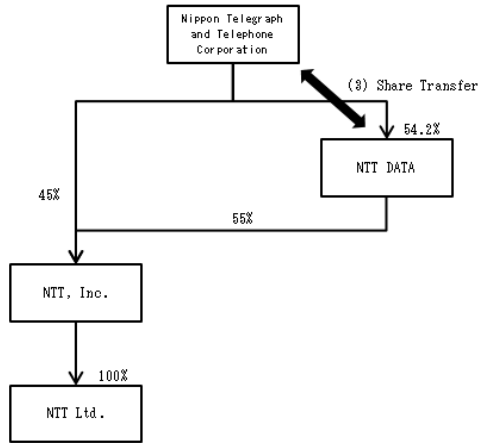

(4) Absorption-type Company Split of NTT DATA’s Domestic Business

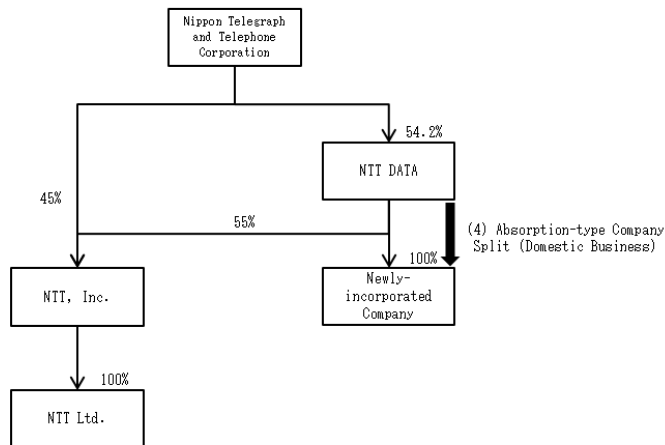

Note: The voting rights ownership ratio of NTT DATA is calculated based on the total number of voting rights (14,023,886) as of September 30, 2021, rounded to one decimal place. The total number of issued shares as of December 31, 2021 was 1,402,500,000.

3. Change in Lower-tier Subsidiary Connected with the Dividends in Kind

(1) Reason and Method for Change

As described in “(1) Dividends in Kind, Etc.” in “2. Outline of the Realignment,” NTT, Inc., a wholly owned subsidiary of the Company, will distribute 760,000,000 common shares of NTT DATA owned by NTT, Inc. to the Company. After that distribution, NTT DATA will become a direct subsidiary of the Company and cease to be a lower-tier subsidiary of the Company.

(2) Type and Total Book Value of Assets to be Distributed

Assets other than money (in kind)	Volume	Book value
Common shares of NTT DATA	760,000,000 shares	7,604,294,760 yen

(3) Matters Regarding Allotment of Assets to be Distributed to the Company

On the effective date of the Dividends in Kind, all of assets to be distributed will be allotted to the Company, which holds all the issued shares of NTT, Inc..

(4) Schedule

Resolution by board of directors of NTT, Inc. May 9, 2022

Resolution by general shareholders meeting of NTT, Inc. June 17, 2022 (target)

Effective date of the Dividends in Kind October 1, 2022 (target)

(5) Outline of the Company Conducting the Dividends in Kind

Please see “(2) Outline of Changing Lower-tier Subsidiary” in “4. Change in Lower-tier Subsidiary Connected with the Absorption-type Company Split (Global Business)” below.

(6) Outline of Changing Lower-tier Subsidiary

(i) Name	NTT DATA Corporation		
(ii) Location	3-3, Toyosu 3-chome, Koto-ku, Tokyo		
(iii) Title and Name of Representative	Yo Honma, Representative Director, President and Chief Executive Officer		
(iv) Type of Business	Consulting, integrated IT solutions, system and software development, maintenance and support, etc.		
(v) Stated Capital	142,520,000,000 yen (as of December 31, 2021)		
(vi) Date of Incorporation	May 23, 1988		
(vii) Shareholders and Shareholding Ratios (As of September 30,	Principal	NTT, Inc.	54.19%
		The Master Trust Bank of Japan (Trust Account)	11.97%
		Custody Bank of Japan, Ltd. (Trust Account)	5.15%
		JP MORGAN CHASE BANK 385635 (Standing	1.30%

2021)	proxy: Mizuho Bank, Ltd.) Custody Bank of Japan, Ltd. (Securities Investments Trust Account) 1.10% NTT Data Employee Shareholding Association 1.02% STATE STREET BANK WEST CLIENT-TREATY 505234 (Standing proxy: Mizuho Bank, Ltd.) 0.81% JP MORGAN CHASE BANK 380072 (Standing proxy: Mizuho Bank, Ltd.) 0.68% STATE STREET BANK AND TRUST COMPANY 505103 (Standing proxy: Mizuho Bank, Ltd.) 0.60% JP MORGAN CHASE BANK 385781 (Standing proxy: Mizuho Bank, Ltd.) 0.58%		
(viii)	Relationship between the Listed Companies and NTT DATA		
Capital Relationship	As of today, NTT, Inc., the wholly owned subsidiary of the Company, owns 760,000,000 common shares of NTT DATA, and the Company counts NTT DATA as its consolidated subsidiary.		
Personnel Relationship	As of today, one employee of the Company serves as a director who is not a member of an audit and supervisory committee, and one director of NTT, Inc., the wholly owned subsidiary of the Company, serves as a director who is not a member of an audit and supervisory committee.		
Business Relationship	The Company has dealings with NTT DATA relating to basic research and development, and services regarding management and operations of the group.		
(ix)	Operating results and financial status (consolidated) of NTT DATA over the most recent three years		
Fiscal Year	Fiscal Year ending March 2019	Fiscal Year ending March 2020	Fiscal Year ending March 2021
Equity attributable to shareholders of the Company (million yen)	925,667	939,683	1,072,899
Total assets (million yen)	2,476,062	2,686,008	2,897,015
Equity attributable to the shareholders of the Company per share (yen)	660.01	670.01	764.99
Sales amount (million yen)	2,163,625	2,266,808	2,318,658
Operating profit (million yen)	147,716	130,937	139,173
Profit attributable to the shareholders of	93,616	75,148	76,843

the Company (million yen)			
Base profit per share (yen)	66.75	53.58	54.79

4. Change in Lower-tier Subsidiary Connected with the Absorption-type Company Split (Global Business)

(1) Reason and Method for Change

As described in “3. Change in Lower-tier Subsidiary Connected with the Dividends in Kind,” NTT DATA will become a direct subsidiary of the Company through the Dividends in Kind. Further, as described in “(2) Absorption-type Company Split of NTT DATA’s Global Business” in “2. Outline of the Realignment,” NTT DATA will conduct the Absorption-type Company Split (Global Business) with NTT, Inc. on the condition that the Dividends in Kind and the Share Split become effective, and NTT DATA will acquire 3,315 common shares of NTT, Inc. as consideration for that transaction. As a result, 49% of the issued common shares of NTT, Inc. will be held by the Company and 51% will be held by NTT DATA, and NTT, Inc. will become a subsidiary of NTT DATA and, accordingly, become a lower-tier subsidiary of the Company. Please note that, as described in “(3) Transfer of NTT, Inc.’s Shares from the Company to NTT DATA” in “2. Outline of the Realignment,” the Company will to conduct the Share Transfer on the condition that the Absorption-type Company Split (Global Business) becomes effective, and thereby 45% of the issued common shares of NTT, Inc. will be held by the Company and 55% will be held by NTT DATA. The company name and representative, etc. of NTT, Inc. after the Absorption-type Company Split (Global Business) will be determined upon consultation between the Company and NTT DATA.

(2) Outline of Changing Lower-tier Subsidiary

(i) Name	NTT, Inc.		
(ii) Location	5-1, Otemachi 1-chome, Chiyoda-ku, Tokyo		
(iii) Title and Name of Representative	Jun Sawada, Representative Director, President and Chief Executive Officer		
(iv) Type of Business	Governance, strategy planning and promoting measures regarding global business of the Company group		
(v) Stated Capital	340,050,979,662 yen (as of March 31, 2022)		
(vi) Date of Incorporation	July 5, 2006		
(vii) Principal Shareholders and Shareholding Ratios	Nippon Telegraph and Telephone Corporation		100.0%
(viii) Relationship between the Listed Company and NTT, Inc.			
Capital Relationship	As of the date hereof, the Company holds 65 common shares of NTT, Inc., and the Company counts NTT, Inc. as its wholly owned subsidiary.		
Personnel Relationship	As of the date hereof, two directors and two executive officers of the Company serve as directors of NTT, Inc., and two auditors of the Company serve as auditors of NTT, Inc..		
Business Relationship	The Company delegates global business promotional operations and the like to NTT, Inc.. Also, NTT, Inc.’s general administrative		

	operations and the like are delegated to the Company.		
(ix)	Operating results and financial status (see note below) of NTT, Inc. over the most recent three years		
Fiscal Year	Fiscal Year ending March 2019	Fiscal Year ending March 2020	Fiscal Year ending March 2021
Net assets/total equity (million yen)	1,116,603 (-)	1,482,629 (-)	1,540,730 (786,300)
Net worth/total assets (million yen)	1,117,302 (-)	1,483,427 (-)	1,541,830 (2,029,483)
Net assets per share / equity attributable to the shareholders of the company per share (million yen)	17,723 (-)	23,166 (-)	23,703 (88)
Sales amount (million yen)	175 (-)	99,465 (897,687)	154,217 (1,058,832)
Operating profit (million yen)	-171 (-)	94,857 (-21,446)	151,586 (9,226)
Ordinary profits/profits before tax (million yen)	-418 (-)	93,782 (-31,563)	150,884 (-2,352)
Net profits/profits attributable to the shareholders of the company (million yen)	-32,864 (-)	104,144 (-33,971)	150,171 (-13,589)
Net profits per share/ basic earnings per share (million yen)	-534 (-)	1,640 (-4)	2,328 (-2)
Dividends per share (million yen)	0 *Ordinary dividend s: 0 Special dividends: 0	2,322 *Ordinary dividend s: 1,627 Special dividends: 695	2,310 *Ordinary dividend s: 2,310 Special dividends: 0

Note: Since NTT, Inc. has not prepared consolidated management indicators, the table above shows individual management indicators (Japanese GAAP) for NTT, Inc., and figures in parentheses show consolidated management indicators (based on IFRS) for NTT Ltd., which is expected to be the only direct subsidiary of NTT, Inc. immediately prior to the consummation of the Absorption-type Company Split (Global Business) on the effective date thereof (October 1, 2022). The consolidated management indicators are internally managed figures after offsetting and eliminating internal transactions, etc. between NTT Ltd. and its subsidiaries and are unaudited figures for reference purpose only (these figures partially include financial figures of companies that will not become subsidiaries under NTT DATA as a result of the Absorption-type Company Split (Global Business)). In addition, because NTT Ltd. was established in July, 2019, no figures are available for the fiscal year ended March 2019. Also, since NTT Ltd. group began to manage figures on a consolidated basis during the FY2020, figures for the balance sheet for the FY2020 do not exist. The amounts of dividends per share are provided based on the amount of dividends resolved at the ordinary and extraordinary general shareholders meetings of NTT, Inc. held for the corresponding fiscal year.

(3) Schedule

Resolution by board of directors of NTT DATA	May 9, 2022
Resolution by board of directors of NTT, Inc.	May 9, 2022
Execution of absorption-type company split agreement	May 9, 2022
Resolution by general shareholders meeting of NTT DATA	June 16, 2022 (target)
Resolution by general shareholders meeting of NTT, Inc.	June 17, 2022 (target)
Effective date of the Absorption-type Company Split (Global Business)	October 1, 2022 (target)

5. Incorporation of the Newly-incorporated Company and Change in Lower-tier Subsidiary Connected with the Absorption-type Company Split (Domestic Business)

(1) Reason and Method for Change

As described in “(4) Absorption-type Company Split of NTT DATA’s Domestic Business” in “2. Outline of the Realignment,” NTT DATA will conduct the Absorption-type Company Split (Domestic Business) after incorporating the Newly-incorporated Company as its wholly owned subsidiary. As a result, the Newly-incorporated Company will become a lower-tier subsidiary of the Company.

(2) Outline of Changing Lower-tier Subsidiary (plan)

(i)	Name	To be determined.
(ii)	Location	To be determined.
(iii)	Title and Name of Representative	To be determined.
(iv)	Type of Business	To be determined.
(v)	Stated Capital	To be determined.
(vi)	Date of Incorporation	October 1, 2022 (target)
(vii)	Principal Shareholders and Shareholding Ratios	NTT DATA 100.0% (plan)
(viii)	Relationship between the Listed Company and the Newly-incorporated Company	
	Capital Relationship	NTT DATA, a lower-tier subsidiary (a direct subsidiary after the Dividends in Kind) of the Company, will hold all shares of the Newly-incorporated Company.
	Personnel Relationship	To be determined.
	Business Relationship	There is no business relationship of note between the Company and the Newly-incorporated Company.

(3) Schedule

Board of directors regarding approval of incorporation the Newly-incorporated Company	May 9, 2022
Incorporation of the Newly-incorporated Company	October 1, 2022 (target)
Board of directors regarding approval of execution of absorption-type company split agreement	May, 2023 (target)
Execution of absorption-type company split agreement	May, 2023 (target)
General shareholders meeting regarding absorption-type company split agreement	June, 2023 (target)
Effective date of the Absorption-type Company Split (Global Business)	July 1, 2023 (target)

6. Acquisition of NTT DATA Shares by the Company through Market Transactions

The Company will acquire shares of NTT DATA up to 60 million shares or 100 billion yen through market transactions, from the perspective of enhancing the cooperation with NTT DATA. This also intends to improve level of the earnings per share (EPS) of the Company shares.

7. **Future Outlook**

The Company is currently investigating the effects of the Realignment on its consolidated performance, and will promptly make an announcement if there is any matter to be disclosed.

For further inquiries, please contact:
INOUE or KAWAMURA
Investor Relations Office
Finance and Accounting Department
Nippon Telegraph and Telephone Corporation
Contact us by email: <https://group.ntt/en/ir/contact/>

End