

**TECHNICAL REQUIREMENTS FOR IMMUNITY OF  
TELECOMMUNICATIONS EQUIPMENT TO INTERFERENCE  
CAUSED BY WIRELESS DEVICES IN  
TELECOMMUNICATION CENTERS**

TR NO. 549002 Edition 1.1

3rd September, 2018

Nippon Telegraph and Telephone Corporation

## Notice

This document applies to equipment in telecommunication centers that is used or provided by the Nippon Telegraph and Telephone Corporation (NTT) Group. It is published by NTT to provide reference information for designers, manufacturers, consultants and suppliers of equipment or systems in telecommunication centers.

With a view to maintaining the quality and reliability of telecommunications services provided by NTT, this document specifies the design target values, test methods, etc., relevant to the minimum acceptable level of radiated immunity to EMI (electromagnetic interference), including RFI (radio frequency interference), for equipment in telecommunication centers.

The content of this document may be changed without notice when relevant standards are revised, new equipment technology is introduced, or equipment requirements are modified.

If you have any questions regarding the content of this document, please contact the following.

EMC Technology Group, Energy Systems Project  
NTT Energy and Environment Systems Laboratories

TEL 0422-59-4222

FAX 0422-59-5681

E-mail: emc-spec-p[at]hco.ntt.co.jp

(please replace “[at]” to “@” mark)

© 2018 NTT

This document may not be copied or reproduced in any form without written permission from NTT.

## Revision History

Edition	Revision Date	Application Date	Reason for Revision
1	18 September,2015	Same as the revision date	First edition
1.1	3rd September 2018	Same as the revision date	Revision of contact address

## Contents

<b>1. OVERVIEW.....</b>	<b>6</b>
1.1 OBJECTIVES .....	6
1.2 SCOPE OF APPLICATION .....	6
1.3 ORGANIZATION OF THIS DOCUMENT .....	6
<b>2. REFERENCES AND TERMINOLOGY .....</b>	<b>6</b>
2.1 REFERENCES .....	6
2.2. TERMINOLOGY.....	7
<b>3. TEST CONDITIONS.....</b>	<b>8</b>
3.1 TESTING CONDITION 1 .....	8
3.2 TESTING CONDITION 2.....	9
<b>SUPPLEMENTARY PROVISION: METHOD OF TESTING THE RADIATED IMMUNITY OF EQUIPMENT IN TELECOMMUNICATION CENTERS.....</b>	<b>11</b>
<b>A-1. TEST FACILITIES .....</b>	<b>11</b>
A-1.1. GENERAL CONDITIONS .....	11
A-1.2. TEST APPARATUS.....	11
A-1.3. VERIFICATION OF THE UNIFORMITY OF THE ELECTRIC FIELD .....	12
A-1.4. TESTING FACILITIES.....	14
A-1.5. INSTALLATION OF THE EUT.....	15
A-1.5.1. INSTALLATION OF A DESKTOP TYPE EUT .....	15
A-1.5.2. INSTALLATION OF A FLOOR-TYPE EUT .....	16
A-1.6. WIRING .....	16
A-1.7. EXECUTION OF TESTS.....	17
A-1.7.1. TESTING CONDITIONS WITHIN THE SEMI-ANECHOIC CHAMBER.....	17
A-1.7.2. TESTING PROCEDURE.....	17
<b>A-2. EVALUATION OF TEST RESULTS.....</b>	<b>19</b>
<b>A-3. TEST REPORT .....</b>	<b>20</b>

## 1. Overview

### 1.1 Objectives

This technical requirement (hereinafter referred to as “TR”) defines the procedure for measuring the radiated immunity (tolerance to radiated electromagnetic effects) of equipment in telecommunication centers, and specifies the minimum radiated immunity level required for such equipment.

This TR is intended to prescribe the minimum radiated immunity required for equipment in telecommunication centers in order to ensure that even when wireless devices are used in the vicinity, the equipment can continue to function as intended without being affected by the electromagnetic emissions of those devices.

### 1.2 Scope of application

This document applies mainly to the equipment in telecommunication centers that is used to provide telecommunication services.

### 1.3 Organization of this document

This document is organized as follows:

- (1) Section 2 describes those terms used in this TR that require explanation, laws and regulations referred to in this document, and relevant information for using this document.
- (2) Section 3 describes test conditions for the radiated immunity of equipment in telecommunication centers.
- (3) The supplementary provision describes the radiated immunity test methods for equipment used in telecommunication centers.

## 2. References and terminology

### 2.1 References

The following standards referred to in this TR describe matters related to test methods, etc. defined in this TR, and through reference in this TR, constitute provisions of this TR. If the date of issue is specified for a standard, no later

modifications or revisions to this standard shall apply. However, affected parties should investigate whether the latest versions of the standards listed below are applicable if they plan to take any action that requires compliance with this TR. If no date of issue is specified for a standard, the latest version of the standard shall apply. Member states of IEC have a list of the latest international standards.

If both JIS standards and IEC standards are referred to below, JIS standards take precedence.

[1] JIS C 60050-161: 1997, International Electrotechnical Vocabulary: Electromagnetic compatibility

[2] IEC 60050-161: 1990, International Electrotechnical Vocabulary. Chapter 161: Electromagnetic compatibility

[3] JIS C 61000-4-3: 2012, Electromagnetic compatibility (EMC) - Part 4-3: Testing and measurement techniques - Radiated, radio-frequency, electromagnetic field immunity test

[4] IEC 61000-4-3: 2010, Electromagnetic compatibility (EMC) - Part 4-3: Testing and measurement techniques - Radiated, radio-frequency, electromagnetic field immunity test

## 2.2. Terminology

In this TR, JIS C 60050-161 (International Electrotechnical Vocabulary regarding electromagnetic compatibility) applies. The following terms are also defined:

- (1) degradation (of performance): unwanted change in the operational performance of the equipment under test caused by electromagnetic disturbances. This does not necessarily mean malfunctioning or severe failure of the equipment concerned.
- (2) equipment under test (EUT): This is a representative unit of equipment in telecommunication centers, or a group (i.e., system) of functionally interacting units of equipment that includes one or more units of host equipment. This is used for the purpose of evaluation.

- (3) equipment in telecommunication centers: equipment or device that is used only in buildings managed by telecommunication providers and is needed to provide telecommunication services.
  - (a) switching systems, transmission systems, IP systems, servers, wireless devices, power supplies, and air-conditioners
  - (b) devices that are directly connected to one of more of the above devices  
e.g.: optical network unit (ONU)
  
- (4) radiated immunity: ability of devices, equipment or systems to function as intended without degradation in performance even in an environment that includes waves from wireless devices or unwanted electromagnetic waves from electric/electronic devices.
  
- (5) JIS: Japanese Industrial Standards Committee. This is established in the Ministry of Economy, Trade and Industry based on the Industrial Standardization Law, and investigates and deliberates on industrial standardization matters.
  
- (6) IEC: International Electrotechnical Commission. This is an international standardization organization that deals with electrical engineering, electronic engineering and related technologies.

### 3. Test conditions

This test shall be carried out under either testing condition 1 or testing condition 2.

#### 3.1 Testing condition 1

Table 1 shows the test frequency, test level and performance criteria (details are given in Supplementary Provision A-2) applied to the EUT under testing condition 1. The test level column shows the electric field strength (root mean square (RMS) value) of non-modulated carrier signals. The test waveform for amplitude modulation and that for pulse modulation shall be applied separately.

Table 1 Test level and performance criteria

Test frequency	Test frequency interval	Test level	Test waveform		Performance criteria
			Amplitude modulation (AM)	Pulse modulation	
2400 - 2485 MHz	1 MHz	30 V/m (no modulation, RMS)	Modulated frequency: 1 kHz; degree of modulation: 80%	Repetition frequency: 217 Hz; duty cycle: 50%	A
5170 - 5330 MHz					
5490 - 5710 MHz					

### 3.2 Testing condition 2

Table 2 shows the test frequency, test level and performance criteria (details are given in Supplementary Provision A-2) applied to the EUT under testing condition 2.

Table 2 Test level and performance criteria

Test frequency* <sup>1</sup>	Test frequency interval	Test level	Test waveform	Performance criteria
2412 - 2472 MHz	20 MHz	Antenna input power, P, defined by $P [\text{mW/MHz}] = 1640/G$ where G is antenna absolute gain* <sup>2</sup>	OFDM modulation waveform that complies with IEEE 802.11g, and has a bandwidth of 20 MHz	A
5180 - 5320 MHz			OFDM modulation wave that complies with IEEE 802.11a, and has a bandwidth of 20 MHz	
5500 - 5700 MHz				

\*1: The test frequency is the central frequency of the bandwidth of the test waveform.



For example, in the case of the 2400 MHz band, tests shall be carried out using 2412 MHz, 2432 MHz, 2452 MHz, and 2472 MHz as the central frequencies of the waveforms applied.

\*2 : Input power,  $P$ , is calculated based on the absolute gain at the central frequency in accordance with \*1 because the antenna absolute gain,  $G$ , varies depending on the frequency.

## Supplementary Provision: Method of testing the radiated immunity of equipment in telecommunication centers

### A-1. Test facilities

#### A-1.1. General conditions

- The test shall be carried out in circumstances like those in which the EUT typically operates.
- In cases where the EUT is typically used with auxiliary apparatus connected, the test shall be carried out with all the ports that can be connected with auxiliary apparatus connected.
- However, any auxiliary apparatus connected to the EUT shall be placed in such a way that it does not affect the EUT during testing.
- The layout of the EUT, etc. and relevant operating conditions shall be recorded in the test certificate accurately.
- In cases where the manufacturer requests the use of external protective devices or protective means in an instruction manual, etc., the test shall be conducted with said external devices or protective means in place and functional.
- The test shall be carried out in such a way that the normal operating environment and power conditions are provided.
- If there is a ground that is independent of the power supply cable, connect to ground in accordance with instructions of the manufacturer.

#### A-1.2. Test apparatus

The test apparatus consists of the following:

- **Semi-anechoic chamber:** The chamber shall be big enough to house the EUT, and shall be a shielded chamber with radio wave absorbers attached to the walls and ceilings.
- **Signal generator:** This generator shall have the following capabilities depending on the testing condition applied:
  - a) Testing condition 1: The signal generator shall be able to generate amplitude modulation signals with a modulated frequency of 1 kHz and a degree of modulation of 80%, and pulse modulation signals with a

repetition frequency of 217 Hz and a duty cycle of 50%.

b) Testing condition 2: The signal generator shall be able to generate OFDM modulation signals with a bandwidth of 20 MHz that comply with IEEE 802.11 a/g standard.

- **Power amplifier:** This amplifier provides power to an antenna so that test waveforms (non-modulated signals and modulated signals) are amplified to achieve the required electromagnetic field strength.
- **Electromagnetic field generating antenna:** double-ridged guide horn antenna or TEM horn antenna.
- **Micro electric field probe:** The probe shall have a pre-amplifier and a photoelectric converter with sufficient immunity to an electric field strength of 30 V/m. This is connected with an optical fiber to a display located outside the room concerned.
- **Power meter:** This is used for calibration of the test level given in test condition 2 (Table 2).
- **Spectrum analyzer:** The spectrum analyzer shall be such that the output bandwidth of the intermediate frequency (IF) is limited by the resolution bandwidth (RBW).
- **Directional coupler:** The directional coupler shall have three ports.

### A-1.3. Verification of the uniformity of the electric field

The uniformity of the electric field generated by the electromagnetic field generating antenna within the irradiated area shall be verified using the procedure described below, and tests shall be carried out using the obtained uniform area as the irradiated area (See Figs. 1 and 2).

- a) Divide the perpendicular plane that is  $100 \pm 5$  mm away from the aperture plane of an electromagnetic field generating antenna into a square grid with 25 mm spacing. Install a micro electric field probe on the central axis of the electromagnetic field generating antenna. The direction of the micro electric field probe shall be the same as the polarization direction of the electromagnetic field generating antenna.
- b) Signals shall be output from the signal generator with a frequency of 2400 MHz.
- c) Adjust the output power of the signal generator so that the electric field strength at the micro electric field probe is 30 V/m, and record the output power of the signal generator at that time.
- d) Measure the electric field with the micro electric field probe at each

intersection of grid lines while keeping the output of the signal generator constant.

- e) Change the test frequency to 2442 MHz, 2485 MHz, 5170 MHz, 5250 MHz, 5330 MHz, 5490 MHz, 5600 MHz, 5710 MHz, and repeat b) through d).
- f) Sort the recorded field strength of values from maximum to minimum values.
- g) The antenna's useable uniform field area is defined by that area which all contiguous probe positions are within 0 to -4 dB of the maximum field strength recorded in steps b) through d).

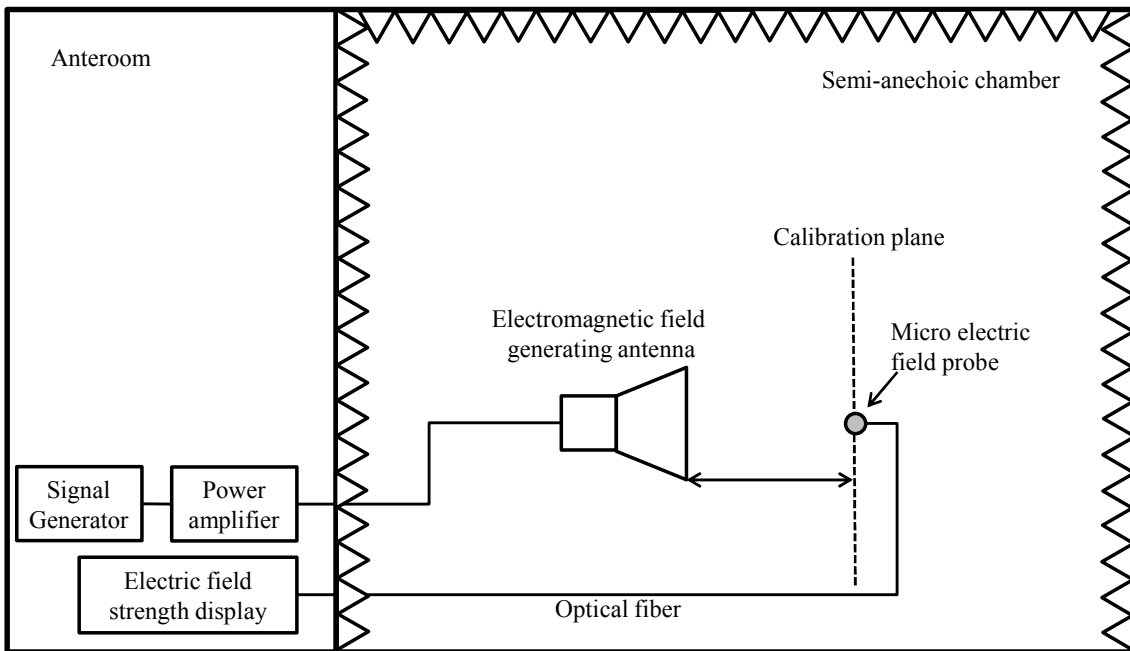

Fig. 1 Measurement system for the calibration of the electric field

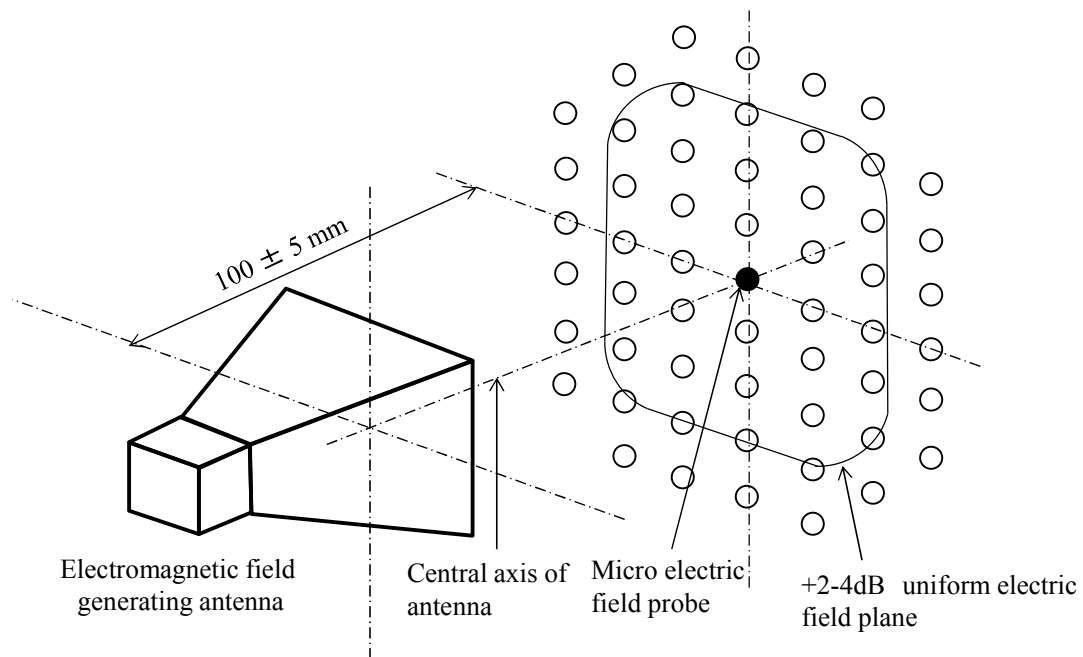

Fig. 2 Calibration to ensure uniformity of the electric field

#### A-1.4. Testing facilities

Tests shall be carried out inside an electromagnetically shielded room (semi-anechoic chamber) in order to prevent test waves from leaking to the outside. Since most types of testing device that collect data are sensitive to the ambient electromagnetic field during a test, it is desirable to have a shielding object between the EUT and the testing device (e.g., place the testing device in an anteroom and the EUT in the semi-anechoic chamber). In addition, the distance between the EUT and the wall or ceiling shall be 80 cm or more in order to minimize the influence of the walls of the semi-anechoic chamber. For an example of appropriate testing facilities, refer to Fig. 3.

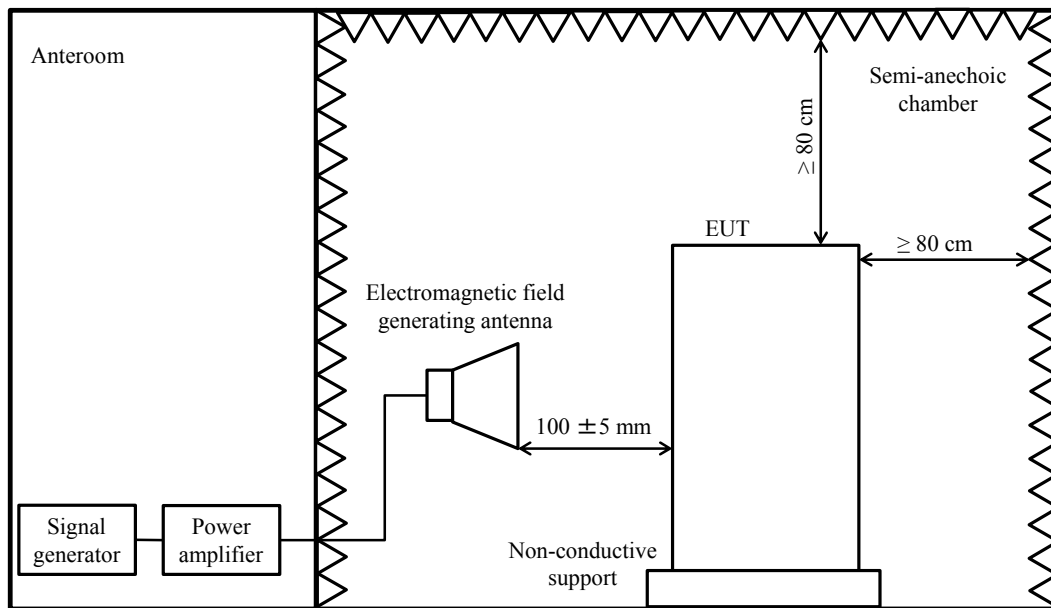

Fig. 3 Setup for test (for a floor-type EUT)

#### A-1.5. Installation of the EUT

Tests are conducted with the EUT installed in a layout that is as similar to a real installation as possible. Wiring shall be provided in accordance with procedures recommended by the relevant manufacturers.

No metal ground plane is required. If the EUT requires a support, the material of the support shall be non-metallic and non-conductive. Generally, a material with a low permittivity, such as rigid polystyrene, is recommended.

The grounding of the chassis and the case of the EUT shall be in accordance with the method recommended by the manufacturer.

Any auxiliary apparatus and connection cables, etc. that are needed for the operation of the EUT shall be in place. A monitoring device or other tools (bit error measurement apparatus, packet error measurement apparatus, etc.) to confirm the normal operation of the EUT shall be connected to the EUT. These shall be installed outside of the area in which the electromagnetic field generating antenna applies an electric field. If no auxiliary apparatus is required, a monitoring device or other tools to confirm the normal operation of the EUT shall be connected to the EUT.

##### A-1.5.1. Installation of a desktop type EUT

Any EUT that is generally placed on a table or desk, but not on an equipment cabinet, shall be installed as follows.

The EUT shall be installed on a non-conductive table with a height of  $0.8 \pm 0.05$  m in the semi-anechoic chamber.

The EUT shall be connected to power and signal wires in accordance with relevant installation manuals.

#### A-1.5.2. Installation of a floor-type EUT

Any UET that is generally placed on the floor or on an equipment cabinet shall be installed as follows.

It is desirable that the EUT be placed on a non-conductive support with a height of  $0.1 \pm 0.05$  m, as shown in Fig. 4. A support made entirely of non-conductive materials shall be used to prevent disturbances in the electromagnetic field in the vicinity of the EUT. For example, if the EUT is of a floor type that can be safely placed on a table, it may be placed on a non-conductive table with a height of 0.8 m for testing. However, the fact that the EUT was placed on a table shall be noted in the test report.

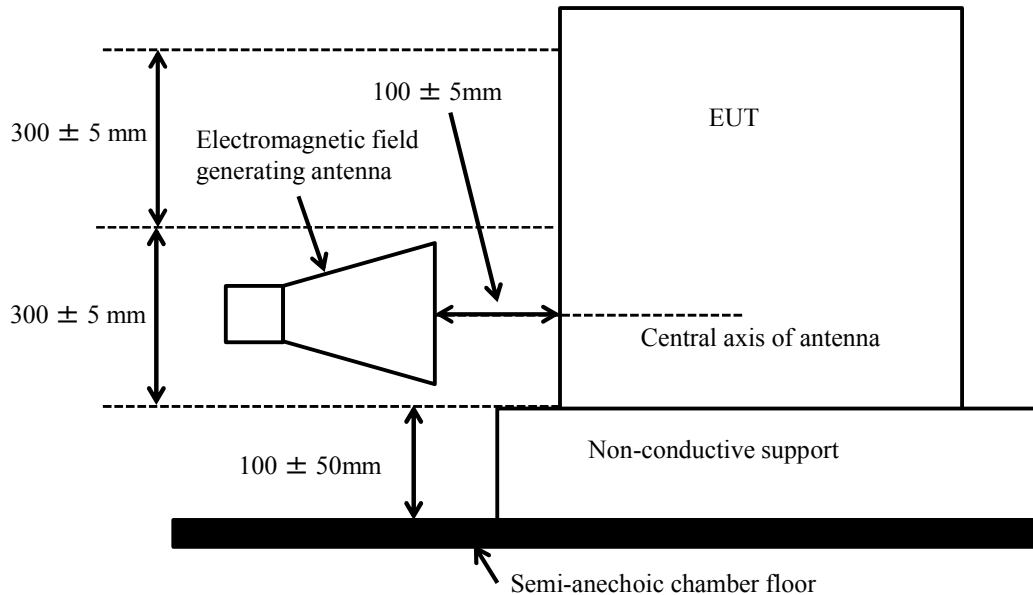

Fig. 4 Installation example of a floor type (side view)

#### A-1.6. Wiring

Connect cables to the EUT in accordance with the installation manual of the EUT

manufacturer. The EUT shall be installed in a state as similar as possible to that when it is actually in use.

Use connection cables and connectors that are specified by the manufacturer. If no connection cables are specified, use unshielded parallel wires. If the manufacturer specifies a wire length of no greater than 3 m, use the specified wire length. If the specified wire length is greater than 3 m or if no wire length is specified, select the appropriate wire length by referring to a typical installation. For example, if cables that connect units of equipment are installed under the floor in the actual use environment, install cables on the floor of the semi-anechoic chamber. If the cable that interconnects EUT units is 3 m or longer, provide an extra length of 30 to 40 cm in the central part of the cables. Double-fold and bundle the cable in that part.

#### A-1.7. Execution of tests

##### A-1.7.1. Testing conditions within the semi-anechoic chamber

The testing conditions within the chamber shall satisfy the operating conditions (temperature, humidity, etc.) defined by the manufacture. If the relative humidity is so high as to cause condensation in or on the EUT or testing apparatus, no tests shall be performed.

##### A-1.7.2. Testing procedure

Conduct a test in accordance with the following (See Fig. 5).

- (1) Divide the surface of the EUT into a grid based on the size of the uniform electric field plane obtained in Supplementary Provision A-1.3.
- (2) Install an electromagnetic field generating antenna  $100 \pm 5$ mm away from the EUT to apply a vertically polarized wave to the EUT. The axis of the radiation direction of the antenna shall be aligned with the center of the grid.
- (3) [When testing condition 1 is to be applied] The test frequency output power of the signal generator for the electromagnetic field generating antenna shall be set to the value obtained through the calibration described in Supplementary Provision A-1.3. For a frequency for which no calibration has been made, set its output power to the value obtained by linearly interpolating the power levels of calibrated frequencies.

[When testing condition 2 is to be applied] A directional coupler shall be connected to the input port of the electromagnetic field generating antenna. Calibrate the



input power to the test level shown in Table 2 using the configuration in Fig. 6 and the formula below.

$$P_{\text{test}}=C_{\text{fwd}}P_{\text{PM}}(1\cdot V_{\text{RC}}^2)$$

where  $P_{\text{test}}$  is the test level [mW/MHz],  $C_{\text{fwd}}$  is a forward coupling coefficient ( $P_3/P_1$ ),  $P_{\text{PM}}$  is the reading on the power meter using a linear scale [mW/MHz], and  $V_{\text{RC}}$  is the voltage standing wave ratio (VSWR) of the antenna connected to port 2.

- (4) Apply an electric field to the EUT, and confirm the correct operation of the EUT using a monitoring device or other checking tools (bit error measurement apparatus, packet error measurement apparatus, etc.)
- (5) Change the test frequency and execute (3) and (4) above.
- (6) Apply a horizontally polarized wave to the EUT, and execute (4) above.
- (7) Direct the electromagnetic field generating antenna to the next grid, and execute (2), (5) and (6) above.

In following the above test procedure, pay attention to the following:

- a) The pulse modulation carrier of each test frequency shall be present for a longer time than is needed for the EUT to operate and respond (e.g., the processing time of the EUT). In any case, it shall be no shorter than 2 seconds.
- b) Tests shall be conducted for all sides. However, no test is needed on any side if one part (panel, etc.) is no smaller than 1.5 times the uniform electric field plane of the electromagnetic field generating antenna, is made of a uniform metal that is 0.25 mm or more thick, and is not to be removed at the time of maintenance work, etc. (e.g., the bottom or ceiling side of the UET).
- c) The electromagnetic field generating antenna shall not be moved while it is applying test signals.

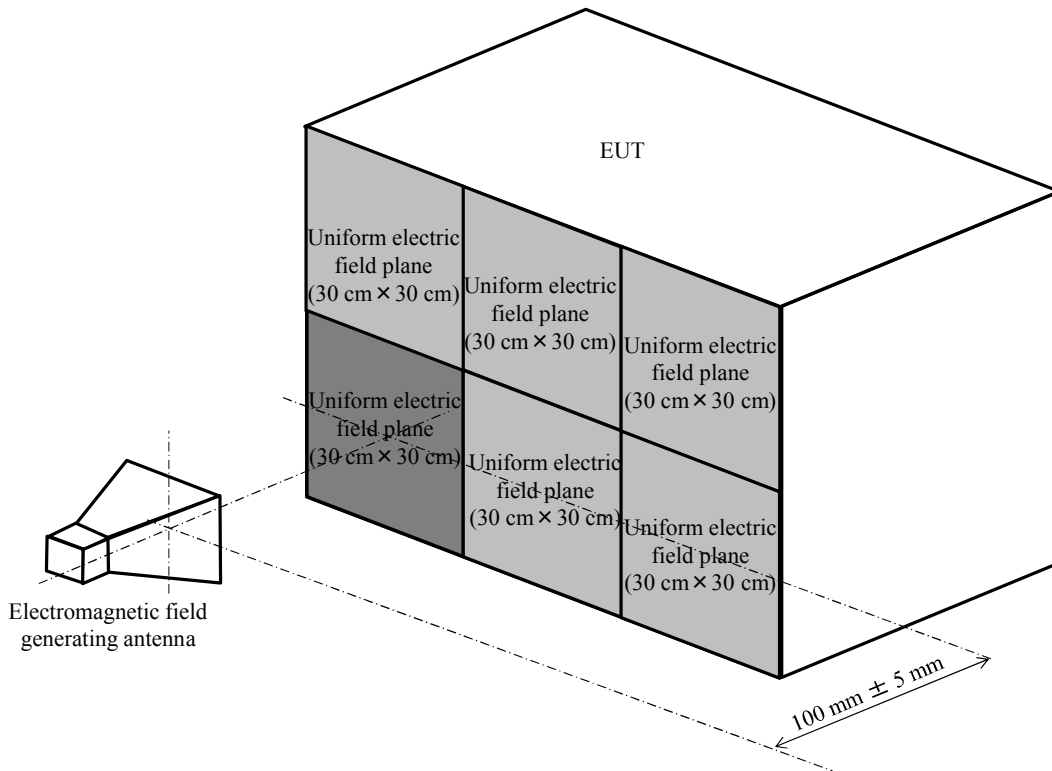

Fig. 5 Method of applying test signals

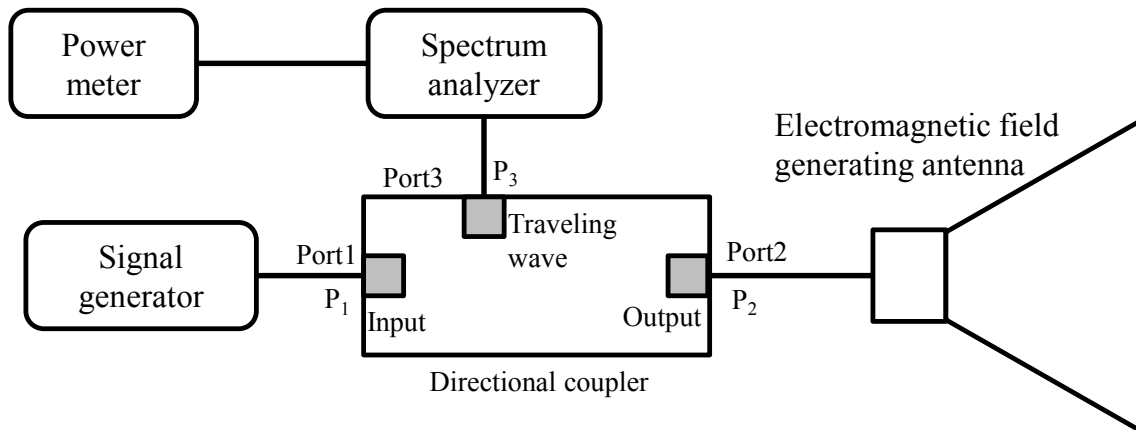

Fig. 6 System for calibrating the antenna input power when testing condition 2 is applied

## A-2. Evaluation of test results

Test results are evaluated in terms of the following performance criteria:

- A The EUT exhibits normal performance within the limits specified by the

manufacturer, the test requester or the purchaser even while test signals are applied.

- B Temporary loss in functionality or temporary degradation in performance occurs that disappears when the test signal is removed. The EUT can return to its normal performance autonomously without requiring any human intervention.
- C Temporary loss in functionality or temporary degradation in performance occurs that requires human intervention for the EUT to return to its normal operation.
- D Unrepairable loss in functionality, degradation in performance, or loss in data caused by damage to hardware or software occurs.

### A-3. Test report

The test report shall include all information needed to replicate the test conducted. In particular, it should include the following items:

- a) Date and place of the test and names of those who carried out the test.
- b) Dimensions of the EUT.
- c) Operating conditions of the EUT.
- d) Whether the EUT is of a desktop type, a floor type or a combination of these.
- e) Height of the support if the EUT is of a floor type.
- f) Position of the electromagnetic field generating antenna.
- g) Type, model number, serial number, and calibration date of the antenna used.
- h) Frequency range and duration of test signal application.
- i) Dimensions of the uniform electric field plane.
- j) All effects observed on the EUT while the test waveform was applied and after the waveform was removed, and the duration of each of these effects.
- k) Grounds for acceptance or rejection.
- l) Complete description (in such a way the conditions can be replicated) of the layout of cables, and the positions and orientations of devices.