

TECHNICAL REQUIREMENTS FOR ELECTROMAGNETIC
DISTURBANCES EMITTED FROM LIGHTING EQUIPMENT
INSTALLED IN TELECOMMUNICATION CENTERS

TR NO. 174001 EDITION 2.2

June 5th, 2023

Nippon Telegraph and Telephone Corporation

NOTICE

This document provides a summary of the basic technical requirements for the limits, test methods, etc. for electromagnetic disturbances emitted from lighting equipment for installation in telecommunication centers operated by Nippon Telegraph and Telephone Corporation (NTT) group. Installation of lighting equipment that complies with the technical requirements described in this document should be decided by responsible organizations in NTT group. This document is intended as reference material to be used by not only lighting equipment designers and manufacturers but also designers or operators of telecommunication center equipment.

The content of this document may be changed without notice when related standards are revised, new equipment technology is introduced, or equipment requirements are modified.

If you have any questions regarding the content of this document, please contact the following sections.

NTT Space Environment and Energy Laboratories
Resilient Environmental Adaptation Research Project
Proactive Environmental Adaptation Technology Group

E-mail: [emc-spec-p\[at\]ml.ntt.com](mailto:emc-spec-p[at]ml.ntt.com)

(Please replace “[at]” to “@” mark)

© 2023 NTT

This document may not be copied or reproduced in any form without written permission from NTT.

Revision History

Edition	Revision Date	Application Date	Reason for Revision
1	June 10th, 2011	Same as the revision date	First edition
1.1	April 1st, 2015	Same as the revision date	Revision of contact address
2	September 18th, 2015	Same as the revision date	Description of limits and measurement methods for transient currents at mains port
2.1	September 3rd, 2018	Same as the revision date	Revision of contact address
2.2	June 5th, 2023	Same as the revision date	Revision of contact address

CONTENTS

1. OVERVIEW	1
1.1 PURPOSE.....	1
1.2 OUTLINE.....	1
1.3 SCOPE	1
2. REFERENCES AND TERMINOLOGY	1
2.1 REFERENCES	1
2.2 TERMINOLOGY	2
3. TECHNICAL REQUIREMENTS.....	4
3.1 LIMITS FOR CONDUCTED DISTURBANCE VOLTAGE AT MAINS PORTS	4
3.2 LIMITS FOR RADIATED DISTURBANCES	5
3.3 LIMITS FOR TRANSIENT CURRENTS AT MAINS PORT	5
4. MEASUREMENT METHODS.....	6
4.1 CONDUCTED DISTURBANCE VOLTAGE AT MAINS PORTS	6
4.2 RADIATED DISTURBANCES	6
4.3 TRANSIENT CURRENTS AT MAINS PORT	7
ANNEX.....	8
ANNEX A : MEASUREMENT OF TRANSIENT CURRENTS AT MAINS PORTS	8

1. Overview

1.1 Purpose

This document prescribes the limits and measurement methods of electromagnetic disturbances for controlling radiated and conducted disturbances emitted from lighting equipment installed in telecommunication centers operated by NTT group.

1.2 Outline

Section 2 describes key terms used, laws and regulations referred to in this document, and relevant information when using this document.

Section 3 describes the limits of electromagnetic disturbances emitted from lighting equipment installed in telecom centers.

Section 4 describes the measurement methods for electromagnetic disturbances emitted from lighting equipment.

Annex describes the measurement methods for transient current from lighting equipment.

1.3 Scope

The scope of this document is any lighting equipment for installation in telecommunication centers. However, any emergency lighting equipment regulated by the Building Standards Act, any emergency exit signs regulated by the Fire Services Act, and lighting equipment that is not operating normally are excluded from the scope of this document. Electromagnetic disturbances due to malfunctions of lighting equipment, for instance the flickering of lighting equipment due to extended use after the manufacturer's suggested lifetime limit, are also out of the scope of this document. To prevent electromagnetic disturbances on telecommunication equipment, renewal of lighting equipment within an appropriate time period is needed.

2. References and terminology

2.1 References

[1] CISPR 15 : 2009, Limits and methods of measurement of radio disturbance characteristics of

electrical lighting and similar equipment.

- [2] **CISPR 16-1-2** : 2006, Specification for radio disturbance and immunity measuring apparatus and methods – Part 1-2: Radio disturbance and immunity measuring apparatus – Ancillary equipment – Conducted disturbances.
- [3] **CISPR 16-2-1** : 2008, Specification for radio disturbance and immunity measuring apparatus and methods – Part 2-1: Methods of measurement of disturbances and immunity – Conducted disturbance measurement.
- [4] **CISPR 22** : 2008, Information technology equipment – Radio disturbance characteristics – limits and methods of measurement. (Interpretation sheet 1: 2009, Interpretation sheet 2: 2010)
- [5] **EN55015** : 2009, Limits and methods of measurement of radio disturbance characteristics of electrical lighting and similar equipment.
- [6] **EN55022** : 2007, Information technology equipment – Radio disturbance characteristics – limits and methods of measurement.
- [7] **J55015** : 2008, Limits and measurement methods of radio disturbance characteristics emitted from electric lighting and similar equipment.
- [8] **IEC61000-4-6** : 2008, Electromagnetic compatibility (EMC) – Part 4-6: Testing and measurement techniques – Immunity to conducted disturbances, induced by radio-frequency fields.

The dated references listed above are the latest versions at the time when this document was published. The latest versions of the references shall be used except for any instructions.

2.2 Terminology

- (1) **telecommunication center**: Buildings owned and supervised by NTT and NTT group in which telecommunication center equipment for providing telecommunication services is installed and operating.
- (2) **lighting equipment**: Lighting equipment mounted on the walls, cells, and/or near the rack for illuminating a room or equipment. There are various types of lamps such as light tube, light emitted diode (LED), and discharge tube. lighting equipment
- (3) **telecommunication center equipment**: Telecommunications equipment or facilities used only within buildings that are supervised by telecommunications operators. The telecommunication center equipment may include;

- (a) Switching, transmission, power supply and radio equipment, router and server.
 - (b) Peripheral equipment directly connected to or used with the equipment listed in (a), e.g., workstations controlling the equipment listed in (a).
- (4) **simple substance**: Simple substance is the smallest unit of the lighting equipment connected some lamps based on specifications. Perform the measurement of the interference wave in a lighting equipment simple substance.
- (5) **radiated disturbances**: The electric-field strength of disturbances unintentionally radiated from lighting equipment working directly in the open air.
- (6) **conducted disturbances**: Unintentional disturbances propagating metal cables (power lines, signal lines etc.).
- (7) **mains ports**: The ports connected to conductors or cables for AC or DC power feeding.
- (8) **conducted disturbance voltage at mains ports**: The voltage of the radio frequency disturbance induced at mains ports.
- (9) **transient current**: Transitional current that appears at mains ports in following cases.
- (a) From the time when the lighting equipment is switched on until it turns on.
 - (b) When the lighting equipment is switched off.
- (10) **CISPR**: French acronym meaning "International Special Committee on Radio Interference". This special committee was established by the International Electrotechnical Commission to study standards for limits, test methods, and test facilities with regard to radiated emission.
- (11) **limits**: Acceptable maximum level of electromagnetic disturbances emitted from equipment when such disturbances are measured using specified measurement methods and operating conditions.
- (12) **equipment under test (EUT)**: The equipment (devices, appliances and systems) subjected to EMC (emission) compliance tests.
- (13) **coupling and decoupling network**: electrical circuit for transferring test signals from injection port to the EUT with a defined impedance and for preventing test signals applied to the EUT from affecting other devices, equipment or systems that are not under test. The circuit is called a CDN for short.
- (14) **artificial mains network, also referred to as a line impedance stabilization network**: A network inserted in the supply mains lead of apparatus to be tested which provides, in a given frequency range, a specified load impedance for the measurement of disturbance voltages and which may isolate the apparatus from the supply mains in that frequency range. This is called a AMN or LISN for short.

- (15) **phase control:** Phase control allows control of the point in the cycle of mains at which equipment is to be switched on or off. The point at which the mains voltage is 0 V is considered phase 0 degrees.
- (16) **correction capacitor:** A capacitor that is inserted into a measuring system in order to eliminate the influence of the mains' impedance. Elimination of this influence is intended to improve repeatability in the measurement of transient currents on lighting equipment.

3. Technical requirements

It is necessary to consider two types of electromagnetic disturbances that are emitted from lighting equipment installed in telecommunication centers: continuous disturbances, (conducted disturbances at mains ports and radiated disturbances) and transitional disturbances (transient current at mains ports). The respective disturbances as measured using the methods specified in Section 4 shall be no greater than the limits specified in Clauses 3.1 to 3.3.

3.1 Limits for conducted disturbance voltage at mains ports

Quasi-peak and average detected disturbance voltages at the mains ports shall be no greater than the values specified in Table 1.

Table 1 Limits for conducted disturbance voltage at mains ports

Frequency range	Detection type	Quasi-peak (dB μ V)	Average (dB μ V)
9 to 50 kHz		110	—
50 to 150 kHz		90 – 80	—
150 to 500 kHz		66 – 56	56 – 46
500 kHz to 5 MHz		56	46
5 to 30 MHz		60	50

Note 1: 1 μ V is taken to be 0 dB μ V.
 Note 2: If quasi-peak value of measurement is less than limit specified for average-value detection, equipment shall be deemed to meet both limits and there is no need to take average-value measurement.
 Note 3: Lower limit shall apply at transition frequency.
 Note 4: Limit shall decrease linearly with logarithm of frequency.
 Note 5: For electrode-less lamps and luminaries, limit in frequency range of 2.51 to 3.0 MHz is not applied in this document. Exemption for Japan described in CISPR 15 is also not applied in this document.

3.2 Limits for radiated disturbances

(1) Limits below 1 GHz

Quasi-peak detected values for the electric-field strength of radiated disturbances shall be no greater than the values at the specified distance given in Table 2.

Table 2 Limits for radiated disturbances (10 m)

Frequency range	Detection type	quasi-peak values
30 to 230 MHz		30 dB μ V/m
230 MHz to 1 GHz		37 dB μ V/m
Note 1: 1 μ V/m is taken to be 0 dB μ V/m. Note 2: Lower limit shall apply at transition frequency. Note 3: Add 10 dB to limit when measurement distance is 3 m. Subtract 10 dB from limit when measurement distance is 30 m. Note 4: Measurement method by means of coupling and decoupling network (CDN) described in CISPR 15 Annex B is not applied in this document because measurement method has not established.		

(2) Limits above 1 GHz

Peak and average detected values for the electric-field strength of radiated disturbances shall be no greater than the values at the specified distance given in Table 3.

If the highest frequency of the internal sources of the lighting equipment under test is less than 108 MHz, measurement shall only be carried out up to 1 GHz. On the other hand, if the highest frequency of the internal sources of the lighting equipment is unknown or clearly greater than 108 MHz, measurement shall be carried out based on Clause 6.2 of CISPR 22 Edition 6.

Table 3 Limits for radiated disturbances (3 m)

Frequency range	Detection type	Peak (dB μ V/m)	Average (dB μ V/m)
1 to 3 GHz		70	50
3 to 6 GHz		74	54
Note 1: 1 μ V/m is taken to be 0 dB μ V/m. Note 2: Lower limit shall apply at transition frequency.			

3.3 Limits for transient currents at mains port

The limit for transient currents that arise at a mains port when a piece of lighting equipment is turned on or off is shown in Table 4. At present, there is no clear guideline specifying the limits of transient currents and the limits are now being investigated by international standardization organizations such as ITU-T. However, a situation may arise where a maintenance worker enters or leaves a telecommunication center turning the lighting equipment in the center on and off. This switching produces a transient current at the mains ports for the lighting equipment. In the past, there have been a number of reports on the malfunction of telecommunication equipment due to this transient current from lighting equipment, and limits have been specified for the transient current

measured using the method specified in Clause 4.3.

Table 4 Limits for transient current

	Limits
Transient current	5 A _{p-p}

4. Measurement methods

This section describes the measurement methods for electromagnetic disturbances emitted from lighting equipment.

4.1 Conducted disturbance voltage at mains ports

(1) Measurement arrangement and procedures

Measurement arrangement and procedure shall comply with CISPR 15, EN55015, or J55015.

(2) Components of lighting equipment and operating conditions

Components of lighting equipment shall be based on normal conditions provided by the manufacturers. If the lighting equipment has twin tubes, measurement shall be carried out with two light tubes.

Operating conditions of the lighting equipment shall comply with clause 6 of CISPR 15, EN55015, or J55015.

(3) Measurement instruments and locations

Measurement instruments and locations shall comply with CISPR 22.

4.2 Radiated disturbances

(1) Measurement arrangement and procedures

Measurement arrangement and procedure shall comply with CISPR 22 or EN55022. For inherent measurement arrangement and lighting equipment procedures, priority should be given to CISPR 15, EN55015, or J55015.

(2) Components of lighting equipment and operating conditions

Components of lighting equipment shall be based on normal conditions provided by the

manufacturers. If the lighting equipment has twin tubes, measurement shall be carried out with two light tubes.

Operating conditions shall comply with clause 6 of CISPR 15, EN55015, or J55015.

(3) Measurement instruments and locations

Measurement instruments and locations shall comply with CISPR 22.

4.3 transient currents at mains port

(1) Measurement arrangement and procedures

Measurement arrangement and procedure shall comply with Annex A.

(2) Components of lighting equipment and operating conditions

Components of lighting equipment shall be based on normal conditions provided by the manufacturers. If the lighting equipment has twin tubes, measurement shall be carried out with two light tubes.

Operating conditions shall comply with clause 6 of CISPR 15, EN55015, or J55015.

(3) Measurement instruments and locations

Measurement instruments and locations shall comply with Annex A.

Annex

Annex A : Measurement of Transient Currents at Mains Ports

A.1 General

This supplementary provision provides the specification of the measurement method used for transient currents at mains ports that arise when lighting equipment is switched on or off in an environment in which the lighting equipment is connected to the mains network and the supply is switched electronically or mechanically.

A.2 Measuring instruments

A.2.1 Oscilloscope

An oscilloscope that can sample at 250 Mega samples per second and can start sampling by means of an external trigger shall be used. There shall be at least two input channels for waveform monitoring, and another channel for trigger input. If a current is monitored with a long sample over a long period, true peaks may not be recorded. Therefore, a peak detection mode shall be selected.

A.2.2 Programmable switch (electronic switch for the on/off control of the power supply)

An electronic switch that can detect the mains phase and can switch the power on or off when the phase of the power supply voltage is 90 or 270 degrees shall be used. An electronic switch shall be able to output a signal to the external trigger input of an oscilloscope that indicates the time at which the power is switched on or off. By supplying this signal to the external trigger input of an oscilloscope, the measurement of the current waveform is enabled in synchronization with the power switching operation. For example, an electronic switch having specifications equivalent to those of PES-50 (Takasago Ltd.), the performance of which is well established, is desirable.

A.2.3 Current probe

A current probe that complies with CISPR 16-1-2, can handle an observed frequency between 30 Hz and 100 MHz, and can measure a peak current of around 30 A shall be used. A current probe having specifications equivalent to those of Tektronix TCP0030A, the performance of which is well established, is desirable.

A.2.4 Differential voltage probe

A differential voltage probe that can measure the frequency of the mains supply shall be used. This probe is mainly used to check that the voltage of the mains supply is at its maximum or minimum level at the time when the power is switched on or off.

If the programmable switch has no function to output the trigger signal, the probe can be used as a trigger.

A.2.5 Correction capacitor

In this test, the commercial mains are also used to supply power to the lighting equipment. However, the impedance of commercial mains depends on the measurement site. A film capacitor (with a capacitance of 10 μF) is inserted between the mains port of the programmable switch and the power cable to eliminate the effect of the mains' impedance at the measurement site. Film capacitors may be connected in parallel to obtain the necessary capacitance and a withstand voltage of 440 V or higher is desirable.

A.2.6 Power impedance simulation circuit

The power impedance simulation circuit shall exhibit the impedance characteristics shown in Fig. A.1 at a frequency between 1 kHz and 10 MHz. This impedance of the simulation circuit indicates the impedance between two lines that is measured at the port of the equipment under test when the port on the programmable switch side is shorted.

The allowable deviation of the impedance shall be $\pm 20\%$, and that of the impedance phase angle ± 10 degrees.

A.3 Measurement system layout

The measurement system is shown in Fig. A.2. One of the hot power lines that supply electricity to the equipment under test is clamped by a current probe. The normal mode current when the switch is turned on and off on the power line is measured as a transient current using an oscilloscope. In addition, a differential voltage probe is connected to the line that supplies power to the equipment under test. The power switch is turned on or off using a programmable switch, which can control switching timing. A circuit that simulates the power impedance is inserted between the equipment under test and the programmable switch. The length of the line between the equipment under test and the power impedance simulation circuit shall be 0.8 m. Make sure that this length is not

exceeded. The power line is clamped by the current probe at a position 0.1 m from the equipment under test. The mains power outlet at the measuring site can be used but a correction capacitor shall be inserted between the power line and the mains port of the programmable switch. The external trigger port of the oscilloscope shall be connected with the external synchronization output signal port of the programmable switch in order to ensure synchronized control at the time when the power is switched on or off. If the programmable switch has no function to output the trigger signal, the differential voltage probe can be used to output a trigger signal.

The equipment under test, the programmable switch, the correction capacity and the power impedance simulation circuit shall be placed on an insulating pedestal or the like so that they will be 0.4 m off from the floor. The floor is made of metal (the reference ground plane) and extends more than 0.5 m from the edge of the equipment under test. Also, the reference ground plane is 2 m x 2m in size or larger. If the equipment under test has a grounding port, it shall be connected to the reference ground plane with as short a conducting wire as possible. No artificial mains network, which is used to measure stationary conducted disturbances, and the load except for the equipment under test shall be incorporated into the transient current measurement system.

A.4 Measurement site

A shielded room shall be used for the measurement of transient currents so that transient currents from the equipment under test can be isolated from ambient noise. A particular site is appropriate for measurement when the ambient noise measured at the site while the power switch is off (i.e., no disturbances are emitted from the equipment under test) using a measurement system that is laid out as described in A.3 is no greater than one-half of the limits specified in Section 3.3 in the main text.

A.5 Measurement procedure

Attach the current probe to one live power wire, and conduct the measurement of transient current. Then, attach the current probe to another live power line, and conduct the same measurement. It is necessary to measure transient currents of each of the two power wires at the time of switching on and switching off when the phase of the mains voltage is 90 and 270 degrees. The times at which the programmable switch turns the power on or off are shown in Fig. A.3. In other words, transient currents shall be measured for a total of 8 combinations. Confirm the operation timing of the programmable switch by measuring the waveform of mains with the difference voltage probe. Calculate the difference between the maximum and minimum levels of the measured transient current waveforms of the 8 combinations, and compare it with the limits.

The maximum or minimum level of the transient current waveform may be observed several microseconds or several seconds from switching on or off of the power. Therefore, the waveform of the transient current shall be measured for at least 3 different time spans on the oscilloscope, such as for about 500 μ s, for about 10 seconds and for some intermediate time spans after switching the power on and off. These time spans are just rough indications. They shall be determined by checking the transient current waveforms so that no significant waveforms shall be overlooked. The number of individual waveform samples observed by the oscilloscope in each recorded measurement shall be 50 kilo samples or greater.

A.6 Certificate of test results

The certificate of test results shall include the following items:

- (1) Title
- (2) Measurement site and the name of the measuring equipment
- (3) The address of the measurement site and the address at which the measuring equipment is located
- (4) The reference number of the certificate of test results, page numbers and the total number of pages
- (5) Name of the measurement requesting entity
- (6) Address of the measurement requesting entity
- (7) Identification number of the equipment under test (EUT), such as the model name and type number
- (8) Dates of measurement
- (9) Measurement results

The certificate shall include transient current waveforms and differences between the maximum and minimum levels of the transient current waveforms for both switching on and off of the power for 3 or more time spans. The certificate may also include phase control and the measurement conditions for the hot wire that is clamped with a current probe for the case where the difference between the maximum and minimum levels of the transient current was the largest, as typical examples. These shall be provided both for a case where power is switched on and for a case where power is switched off.

- (10) The name and affiliation of the person authorized to issue the certificate of test results, and

his/her signature or seal

(11) Ambient conditions

(12) Measurement conditions

- Names, model numbers and serial numbers of measuring instruments and equipment
- Measurement system layout (figures, photos, etc.)

(13) Whether the measurement results comply with the limit requirements specified in TR174001

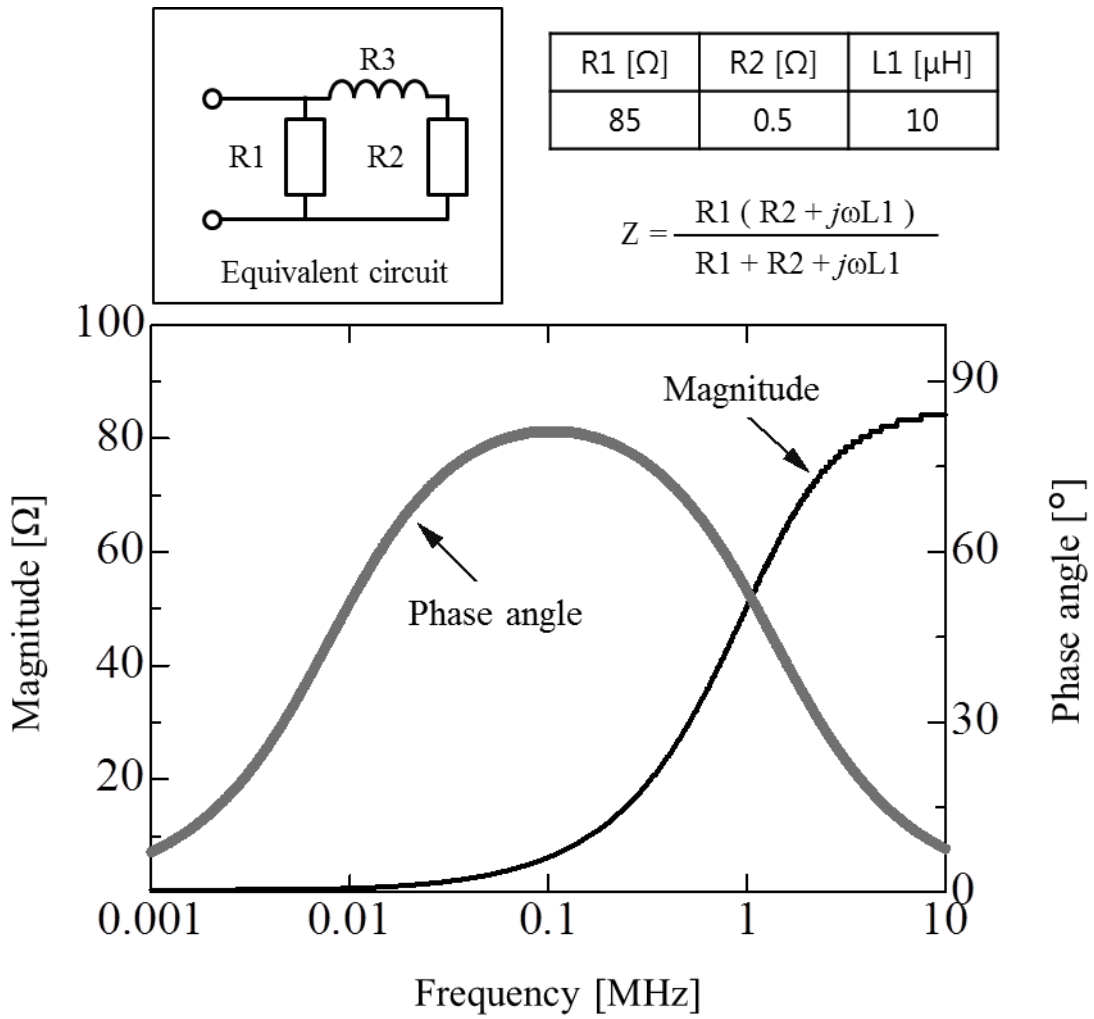

Fig. A.1 Impedance characteristics of power impedance simulation circuit

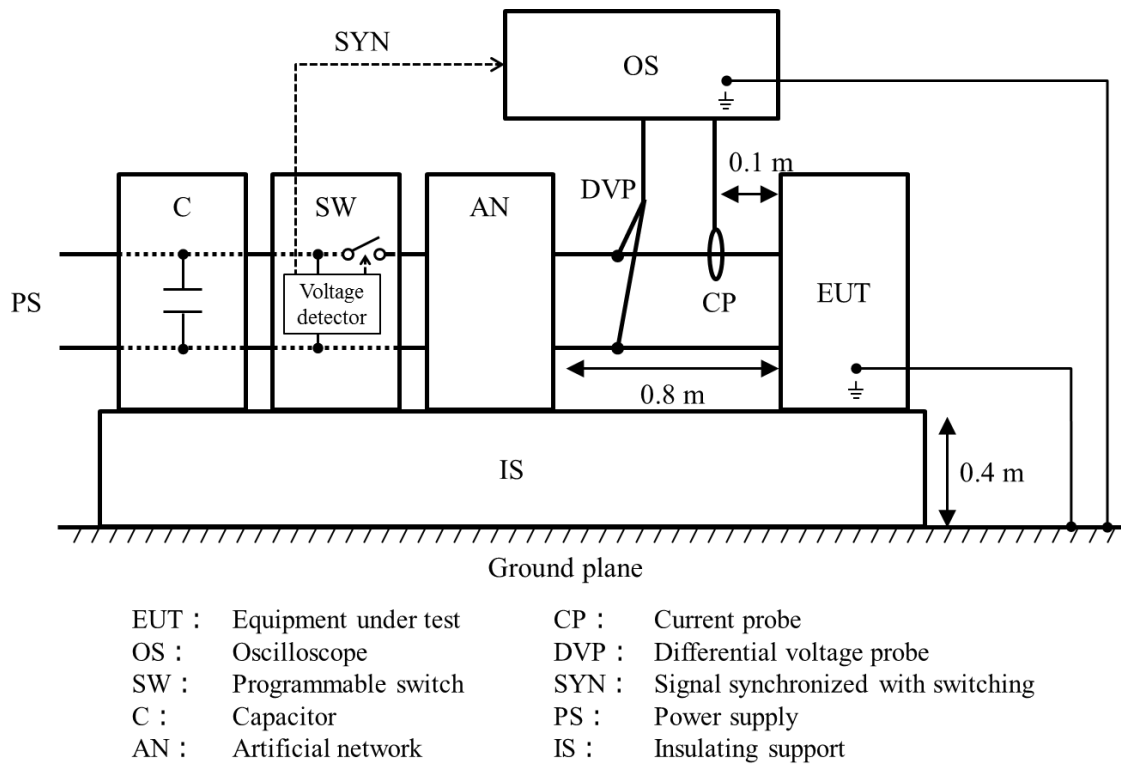
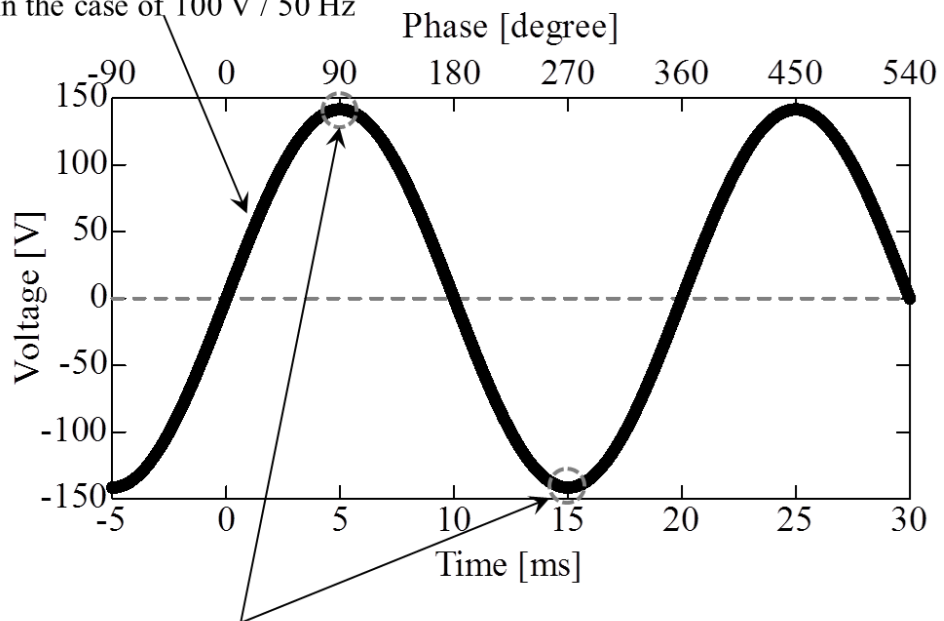

Fig. A.2 Measurement system of transient current

Voltage waveform of commercial power supply
in the case of 100 V / 50 Hz



The timing at which the programmable switch turns the power on or off

Fig. A.3 Example of voltage waveform